

PRIMER IN FIBER OPTICS

0.1 HISTORY OF FIBER OPTICS

The concept of optical communications goes far back into history. The sending of messages by light is certainly as old as the first signal fires or smoke signals, and has continued, in more recent history, in the use of signal lamps for communication between ships at sea. However, the first patents for an optical communications system were filed in 1880. At that time, Alexander Graham Bell obtained patents on the photophone and demonstrated communication on a beam of light at a distance of 200 meters. The photophone, shown in **Fig.0.1**, used a photosensitive selenium cell to detect variations in the intensity of a beam of light. However, all of these methods mentioned here depend on the atmosphere as the transmission medium, and anyone who has ever driven on a foggy day knows how unreliable that is.

A waveguide made of a non-conducting material which transmits light (a dielectric), such as glass or plastic, would provide a much more reliable transmission medium, because it is not subject to the variations of the atmosphere. The guiding of light by a dielectric medium is also not a new idea. In 1870, John Tyndall showed that light could be guided within a stream of water. Tyndall's experiment is illustrated in **Fig.0.2**. By 1910, Hondros and Debye had developed a theory of dielectric waveguides.

The breakthrough which has made the optical fiber waveguide the leading contender as the transmission medium of choice for current and future communications systems was triggered by two events. The first was the demonstration of the first operating laser in 1960. The second was a calculation, in 1966, by a pair of scientists, Charles Kao and George A. Hockham, speculating that optical fiber waveguides could compete with the existing coaxial cables used for communications if fibers could be made that would transmit 1% of the light in them over a distance of 1 kilometer (km). It is important to note that at that time the light energy which was transmitted would be down to 1% of its initial value after only 20 meters in the best existing fibers and that no materials expert was on record predicting that the required high-quality transmission could be achieved.

Many research groups began to actively pursue this possibility, however. In 1970, Corning Glass Works investigated high-silica glasses for fibers and was the first to report a transmission greater than 1% over a distance of 1 km. This group later increased the transmission to greater than 40% over 1 km. Today, transmissions in the range of 95-96% over 1 km are being achieved. For comparison, if ocean water had an optical transmission of ~79% through each km of depth, one could see to the bottom of the world's deepest oceans with the naked eye. The progress in high-transmission fibers is traced in **Fig.0.3**.

The achievement of low-loss transmission, along with the additional advantages of large information carrying capacity, immunity from electromagnetic interference, and small size and weight, has created a new technology. Optical

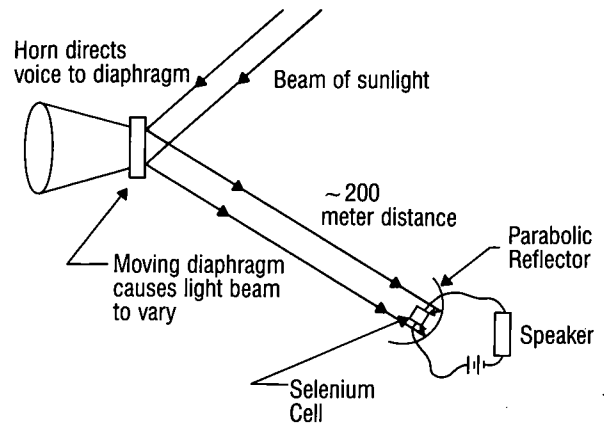

Figure 0.1. Schematic diagram of Alexander Graham Bell's photophone.

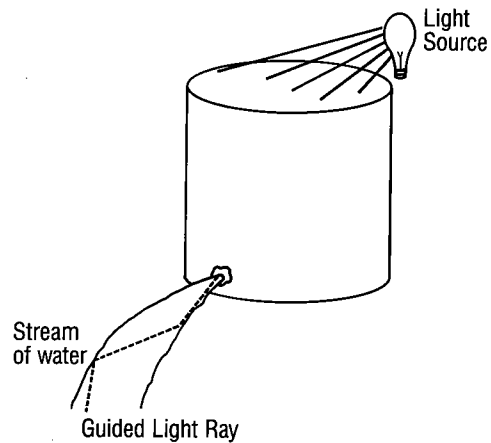

Figure 0.2. Tyndall's experiment showing that a stream of water will guide a beam of light.

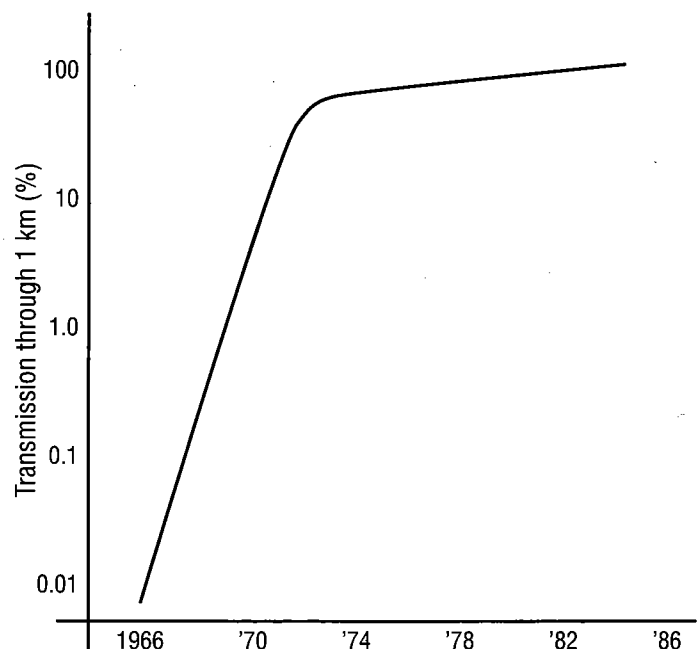

Figure 0.3. Progress in optical fiber transmission. The last two data points represent results near the theoretical limits at 0.85 and 1.55 μm .

fiber has become the medium of choice for communications applications. For example, the TAT-8 (Trans-Atlantic Telephone #8) system, scheduled for completion in 1988, will be a 6500-km all-fiber link which will bring trans-Atlantic telephone capacity to the equivalent of 20,000 voice channels. Compare this with TAT-1, completed in 1955, which carried 50 voice channels over coaxial cable. Also, Pacific Bell has announced plans to convert all of its cables to optical fiber. They plan to have all long-distance calls carried by fiber by 2005 and plan to have fully converted to an all-fiber system by 2025. Optical fiber is also being used extensively in Local Area Networks (LAN's), which are used for voice or data communications within or between buildings. Many new buildings are now being built with fiber installed in their framework for future LAN use.

Optical fiber is also used in sensor applications, where the high sensitivity, low loss, and electromagnetic interference immunity of the fibers can be exploited. Optical fibers are versatile and sensors can be designed to detect many physical parameters, such as temperature, pressure, strain, and electrical and magnetic fields, using either the power transmission properties of multimode fibers or the phase sensitive properties of single-mode fibers. Another application of optical fiber is beam delivery for medical uses. Lasers are now being investigated for use in surgery and diagnostics and optical fiber is being used to deliver beams to sites within the human body.

0.2 GEOMETRICAL OPTICS AND FIBER OPTICS

To understand what is occurring in these projects in fiber optics, it is necessary to understand some basic concepts of optics and physics. This section is intended to introduce these ideas for those who may not have studied the field and to review these ideas for those who have. The student-experimenter is urged to seek additional information in the references at the end of this handbook.

0.2.1 LIGHT AS AN ELECTROMAGNETIC FIELD

The light by which we see the world around us is a part of the range, or spectrum, of electromagnetic waves that extends from radio frequencies to high power gamma radiation. (Fig.0.4) These waves, a combination of electric and magnetic fields, which can propagate through a vacuum, have as their most distinguishing features their wavelength and frequency of oscillation. The range of wavelengths for visible light is from about 400 nanometers (nm) to about 700 nm. (A nanometer is one billionth of a meter.) In most of the work done in the field of fiber optics, the most useful sources of electromagnetic radiation emit just outside the visible in the near infrared with wavelengths in the vicinity of 800 to 1500 nm.

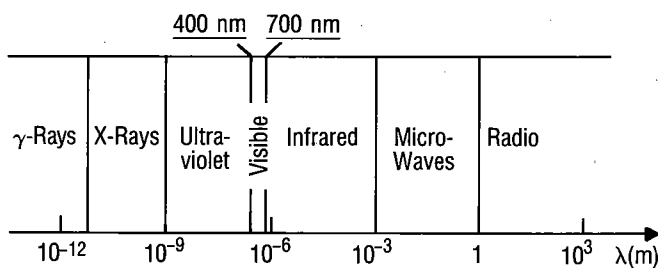

Figure 0.4. The electromagnetic energy spectrum.

It can be difficult to follow what happens in an optical fiber system if the progress of light through the system is depicted in terms of the wave motion of the light. For the simplest cases it is easier to think of light traveling as a series of rays propagating through space. The experience of seeing the sun's rays streaming through the clouds on a partially cloudy day provides a familiar example of light as a collection of rays.

In a vacuum, light travels at approximately 3×10^8 meters per second. In material media, such as air or water or glass, the speed is reduced. For air, the reduction is very small; for water, the reduction is about 25%; in glass, the reduction can vary from 30% to nearly 50%.

0.2.2 LIGHT IN MATERIALS

In most cases, the results of the interaction of an electromagnetic wave with a material medium can be expressed in terms of a single number, the index of refraction of the medium. The **refractive index** is the ratio of the speed of light in a vacuum, c , to the speed of light in the medium, v ,

$$n = c/v. \quad (0-1)$$

Since the speed of light in a medium is always less than it is in a vacuum, the refractive index is always greater than one. In air, the value is very close to one; in water, it is about $4/3$ ($n = 1.33$); in glasses, it varies from about 1.44 to about 1.9.

There are some qualifications to the simple picture presented here. First, the refractive index varies with the wavelength of the light. This is called **wavelength dispersion**, which will be discussed in **Project #8**. Second, not only can the medium slow down the light, but it can also absorb some of the light as it passes through.

In a homogeneous medium, that is, one in which the refractive index is constant in space, light travels in a straight line. Only when the light meets a variation or a discontinuity in the refractive index will the light rays be bent from their initial direction.

In the case of a variation in the refractive index within a material, the behavior of the light is governed by the way in which the index changes in space. For example, the air just above a road heated by the sun will be less dense than the air further from the road. Since the refractive index increases with density, the refractive index of the air increases with height. This is called a **refractive index gradient** and is, in this case, equivalent to having an extended prism above the road with its vertex pointing downwards (see Fig.0.5). Light coming from an object down the road will not only travel directly to the observer's eye, but some of the light from the

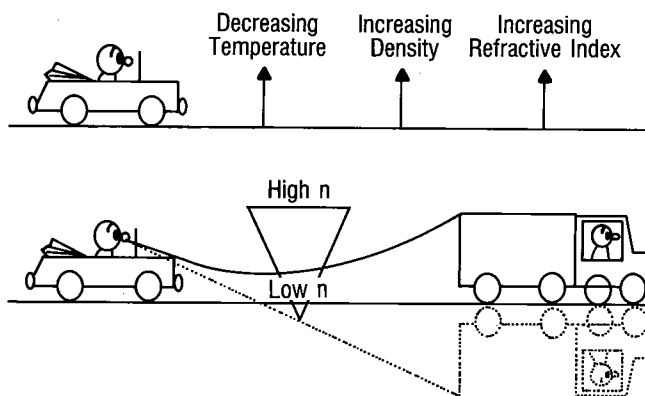

Figure 0.5. Bending of light rays by a refractive index gradient, using the mirage on a heated road as an example.

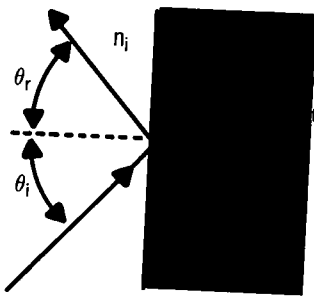

Figure 0.6. Geometry of reflection and refraction.

object that would normally be absorbed by the road is bent toward the observer. The result is that someone looking down the road will see a reflection, called a mirage, of a distant object on the road, as if it were reflected in a pool of water. This gradual bending of light by a refractive index gradient is used in fiber optics to increase the information carrying capacity of fibers and to provide a very compact lens for fiber optic systems.

If the change in refractive index is not gradual, as in the case of the refractive index gradient, but is, instead, an abrupt change like that between glass and air, the direction of light is governed by the Laws of Geometrical Optics. If the angle of incidence, θ_i , of a ray is angle between an incident ray and a line perpendicular to the interface at the point where the light ray strikes the interface (Fig. 0.6), then:

1. The angle of reflection, θ_r , also measured with respect to the same perpendicular, is equal to the angle of incidence:

$$\theta_r = \theta_i \quad (0-2)$$

2. The angle of the transmitted light is given by the relation:

$$n_i \sin(\theta_i) = n_t \sin(\theta_t) \quad (0-3)$$

The first of these relations is known as the **Law of Reflection**; the second as the **Law of Refraction** or **Snell's Law**.

It is useful to refer to a material whose refractive index is greater than another as being optically denser and one whose refractive index is less as being rarer. Thus, light traveling into an optically denser medium would be bent toward the normal, while light entering an optically rarer medium would be bent away from the normal. In Fig. 0.7, a series of rays in a dense medium are incident on an interface at different angles of incidence. Ray #1 is refracted at the interface to a rarer medium according to Snell's Law. Ray #2 is incident at an angle such that the refracted angle is 90° . Ray #3 is incident at an even larger angle. If the angle of incidence of Ray #3 is inserted into Snell's Law, the sine of the angle of transmission will be found to be greater than one! This can not happen. Instead, all of the light is reflected back into the incident medium. There is no light transmitted into the second medium. The light is said to be **totally internally reflected**. For all angles of incidence greater than a critical angle, total internal reflection will occur. This **critical angle** occurs at the angle of incidence at which the transmitted ray is refracted along the surface of the interface (the case illustrated by Ray #2). Setting the angle of transmission equal to 90° , the critical angle, θ_{crit} , is found from Eq. 0-3 to be:

$$\sin(\theta_{crit}) = n_t/n_i \quad (0-4)$$

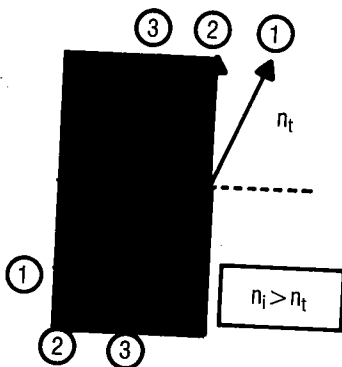

Figure 0.7. Geometry of total internal reflection. Ray #1 is at less than the critical angle. Ray #2 is at the critical angle. Ray #3 is totally internally reflected.

In the ray picture, the concept of total internal reflection makes the interface look like a perfect mirror. If this process is examined in terms of wave propagation, theory predicts and experiment confirms that a weak electromagnetic field exists in the rarer medium, but it decays rapidly with distance from the interface and no light energy is transmitted to the rarer medium. This field is called an **evanescent field**. However, if another optically dense material were located very close to the material in which the total internal reflection were occurring (within a wavelength or so) some of the light energy could be coupled out of the first medium across the small gap and into the second dense medium. This process is called **frustrated total internal reflection** since the usual reflection is frustrated by the location of the material next to the interface. Frustrated total internal reflection is responsible for the operation of a component in fiber optic systems called a bidirectional coupler. This component is studied in **Project #7** and used in subsequent projects.

0.2.3 LIGHT IN OPTICAL FIBERS

Once you understand total internal reflection, you understand the illuminated stream shown in **Fig 0.2** of **Section 0.1**. Light traveling through the water is reflected off of the surface of the water-air interface and trapped inside the stream. The same thing will happen to a glass rod or thread. Optical fibers are a little more complicated than this, however.

If one were to use a fiber consisting of only a single strand of glass or plastic, light could be lost at any point where the fiber touched a surface for support. Thus, the amount of light that could be transmitted would be dependent on the methods used for holding the fiber. The output of the fiber would also be affected by any movement of the fiber during its use. To eliminate these problems, the central light-carrying portion of the fiber, called the **core**, is surrounded by a cylindrical region, called the **cladding** (**Fig 0.8**). The cladding is then covered with a protective plastic jacket. Since the refractive index difference between the core and the cladding is less than in the case of a core in air, the critical angle is much bigger for the clad fiber. The index of the cladding, n_{cl} , is still less than the index of the core, n_{core} , because total internal reflection will occur only when $n_{core} > n_{cl}$. Looking at a cross-section of the fiber in **Fig.0.8**, one sees that the cone of rays that will be accepted by the fiber is determined by the difference between the refractive indices of the core and cladding. The **fractional refractive index difference** is given by

$$\Delta = (n_{core} - n_{cl})/n_{core} \quad (0-5)$$

Because the refractive index of the core is a constant and the index changes abruptly at the core-cladding interface, the type of fiber in **Fig. 0.8** is called a **step-index fiber**.

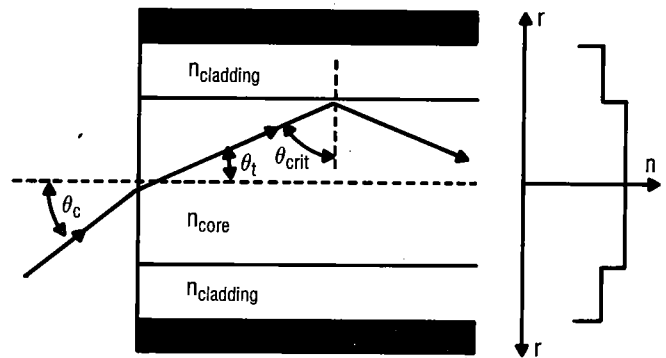

Figure 0.8. Step-index fiber. The refractive index profile is shown at the right. The geometry for derivation of the numerical aperture is given.

The definition of the critical angle can be used to find the size of the cone of light that will be accepted by an optical fiber with a fractional index difference, Δ . In Fig. 0.8 a ray is drawn that is incident on the core-cladding interface at the critical angle. If the cone angle is θ_c , then by Snell's Law,

$$\begin{aligned} n_i \sin \theta_c &= n_{\text{core}} \sin \theta_t = n_{\text{core}} \sin (90^\circ - \theta_{\text{crit}}) \\ &= n_{\text{core}} \cos (\theta_{\text{crit}}) \\ &= n_{\text{core}} \sqrt{1 - \sin^2(\theta_{\text{crit}})} \end{aligned}$$

From Eq. 0-4, $\sin (\theta_{\text{crit}}) = n_{\text{cl}}/n_{\text{core}}$, so

$$n_i \sin \theta_c = \sqrt{n_{\text{core}}^2 - n_{\text{cl}}^2} \quad (0-6)$$

The **numerical aperture**, NA, is a measure of how much light can be collected by an optical system, whether it is an optical fiber or a microscope objective lens or a photographic lens. It is the product of the refractive index of the incident medium and the sine of the maximum ray angle.

$$NA = n_i \sin (\theta_{\text{max}}) \quad (0-7)$$

In most cases, the light is incident from air and $n_i = 1$. In this case, the numerical aperture of a step-index fiber is, from Eqs. 0-6 and 0-7,

$$NA = \sqrt{n_{\text{core}}^2 - n_{\text{cl}}^2} \quad (0-8)$$

When $\Delta \ll 1$, Eq. 0-8 can be approximated by

$$\begin{aligned} NA &= \sqrt{(n_{\text{core}} + n_{\text{cl}})(n_{\text{core}} - n_{\text{cl}})} \\ &= \sqrt{(2 n_{\text{core}})(n_{\text{core}} \Delta)} = n_{\text{core}} \sqrt{2 \Delta} \end{aligned} \quad (0-9)$$

The condition in which $\Delta \ll 1$ is referred to as the **weakly-guiding approximation**. The NA of a fiber will be measured in **Project #1**.

In Fig. 0.9, two rays are shown. One, the **axial ray**, travels along the axis of the fiber; the other, the **marginal ray**, travels along a path near the critical angle for the core-cladding interface and is the highest-angle ray which will be propagated by the fiber. At the point where the marginal ray hits the interface the ray has traveled a distance L_2 , while the axial ray has traveled a distance L_1 . From the geometry, it can be seen that

$$\sin \theta = n_{\text{cl}}/n_{\text{core}} = L_1/L_2 \quad (0-10)$$

The length L_2 is a factor $n_{\text{cl}}/n_{\text{core}}$ larger than L_1 in the case shown in the figure. For any length of fiber L the additional distance traveled by a marginal ray is

$$\delta L = (n_{\text{core}} - n_{\text{cl}}) L/n_{\text{cl}} \quad (0-11)$$

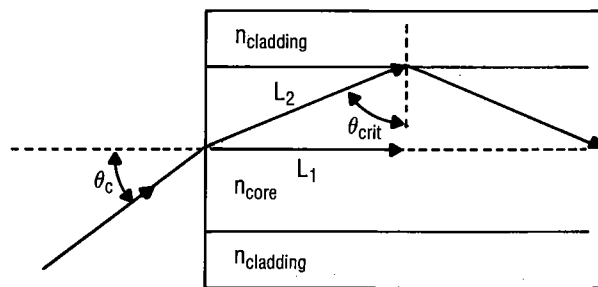

Figure 0.9. The geometry for derivation of the differential delay of a step-index fiber.

Eq. 0-11 can be simplified to $\delta L = \Delta L$. The additional time it takes light to travel along this marginal ray is

$$\delta t = \delta L/v = \Delta L n_{\text{core}}/c. \quad (0-12)$$

Therefore, a pulse with a length t representing one bit of information will be lengthened to $t + \delta t$. This **differential time** between axial and marginal rays will cause a pulse to smear and thereby limit the number of pulses per second that could be sent through a fiber and distinguished at the far end. In such a case, the system may be limited not by how fast the source can be turned on and off or by the speed of response of the detector, but by the differential time delay of the fiber. This smearing of pulses can be remedied through the use of graded-index or single-mode fibers.

Earlier, it was noted that light rays can be deflected by variations in the refractive index of a medium as well as by encountering an abrupt interface between two indices. There are a number of methods of creating controlled index gradients. Some involve introducing impurities into thin layers of glass as they are laid down on a substrate. This is not a continuous process since the refractive index within each layer is nearly constant. The resulting variation of refractive index in a fiber resembles that of a series of concentric tree rings rather than a smooth change in the index. Other techniques involve the removal of material from the base glass by some type of chemical method. Fibers whose cores have such an index gradient are called **graded-index fibers**. In our discussion, we will not make a distinction between these processes, but instead assume that the graded-index profiles are smooth and exactly conform to theory. In real graded-index optical fibers this may not be correct and such departures from the ideal gradient will affect their performance.

Once the refractive index gradient can be controlled through manufacturing processes, it is up to the designer of optical fibers to determine the most useful **refractive index profiles**, $n(r)$, the variation of index with radial distance in the core. This usually fits a power law profile given by

$$n^2(r) = n_0^2 [1 - 2\Delta (r/a)^\alpha], \quad (0-13)$$

where n_0 is the index of refraction at the center of the core, and Δ is the fractional index difference defined earlier in Eq. 0-5, but with n_0 now substituting for n_{core} . The parameter, α , is the exponent of the power law and determines the shape of the graded-index profile. When $\alpha = \infty$, the profile is that of a step-index fiber. For $\alpha = 2$, the profile is parabolic (**Fig. 0.10**). This is the profile found in most telecommunications graded-index fibers, because this profile eliminates the differential time delay between axial and marginal rays. The numerical aperture of a graded-index fiber is the same as that of a step-index fiber only for rays entering on the fiber axis. For rays entering at other points on the core, the local numerical aperture is less because the local index, $n(r)$, must be used in Eq. 0-8. In the case of the parabolic graded-index fiber, the total amount of light which can be collected is one half of that which can be collected by a step-index fiber with the same Δ .

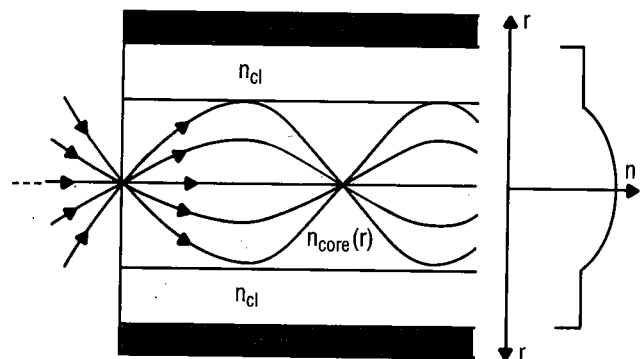

Figure 0.10. Graded-index fiber. The refractive index profile is shown at the right. Diverging rays are refocused at a point further down the fiber.

Without plunging into the mathematics needed to prove that graded-index fibers with a parabolic profile remove differential delay, it is possible to get a qualitative feel of why the smearing of light pulses in such a fiber would be reduced. Instead of the rays bouncing off of the core-cladding interface as in step-index fibers, rays follow a gently curving path in graded-index fibers. In those with a parabolic profile, this path is sinusoidal. That is, the path can be described as a sine function in space. It would seem that light paths which have a large radial amplitude are still longer than the path down the axis of the fiber. But because of the refractive index gradient, the velocity of the light at the center of the fiber is smaller than the velocity of the light near the edge of the core. Although the light that travels near the edge of the fiber has to go farther, it travels faster and arrives at the end of the fiber at the same time as the light travelling down the center of the fiber. If the length of the fiber is L and the speed of light down the center of the fiber is $v = c/n_0$, then the time for a pulse to travel to the end of the fiber is $t = L/v = n_0 L/c$. For light travelling a sinusoidal path, the length traveled will be L'' and the time to travel to the end of the fiber is $t = n(r,z)L''/c$. The product of the geometrical path and the refractive index is called the optical path length. If the optical path length, $n(r)L$, is the same for all paths, there will be no differential delay in the time the rays take to travel through a fiber. For all optical path lengths to be equal, the profile must be parabolic ($\alpha = 2$).

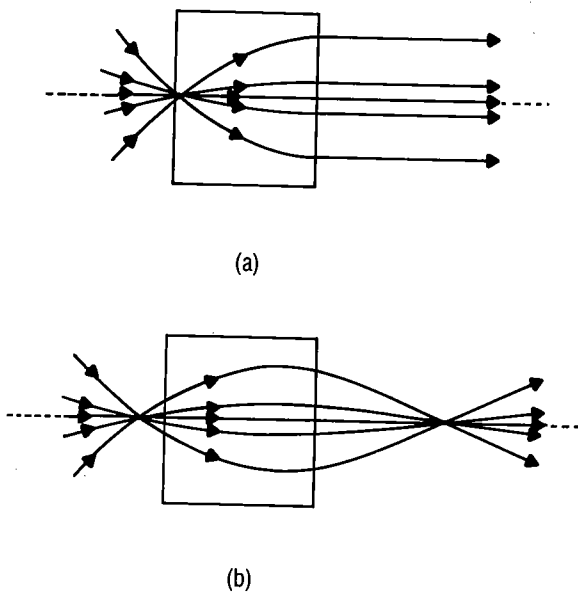

Figure 0.11. Graded-index (GRIN) lens. (a) 0.25 pitch lens. (b) 0.29 pitch lens.

0.2.4 GRADED-INDEX LENSES

One thing to note in Fig. 0.10 is that a fan of rays injected at a point in a graded-index fiber spreads out and then recrosses the axis at a common point just as rays from a small object are reimaged by a lens. The distance it takes for a ray to traverse one full sine path is called the pitch of the fiber. The length of the pitch is determined by Δ , the fractional index difference.

If a parabolic graded-index fiber is cut to a length of one quarter of the pitch of the fiber, it can serve as an extremely compact lens (sometimes called a **GRIN lens**, for GRAded-INDEX) for fiber applications (Fig. 0.11). By positioning the output of a fiber at the face of the short fiber length, light from the lens will be collimated, just as diverging light at the focal point of a lens is collimated. Because its properties are set by its length, this graded-index lens is referred to as a **quarter-pitch or 0.25 pitch lens**.

In some cases, it is not collimation of light which is required, but focusing of the fiber output onto a small detector or focusing of the output of a source onto the core of a fiber. The easiest way of accomplishing this is to increase the length of the GRIN lens slightly to 0.29 of a pitch (**Fig.0.11**). This enables the fiber optic system designer to move the source back from the lens and have the transmitted light refocus at some point beyond the lens. This is particularly useful for coupling sources to fibers and fibers to detectors. Both 0.25 and 0.29 pitch GRIN lenses will be used in **Projects #5, 7, 8, 9, and 10**.

0.3 WAVE OPTICS AND MODES IN OPTICAL FIBERS

Although the ray picture of light propagation through a fiber is easy to depict, it does not reveal some of the interesting properties of light in optical fibers, particularly in those fibers where the core size is on the order of the wavelength of light.

0.3.1 WAVE FIELDS IN A FIBER

The laws governing the propagation of light in optical fibers are Maxwell's equations, the same laws that describe the propagation of light in a vacuum or any medium. When information about the material constants, such as the refractive indices, and the boundary conditions for the cylindrical geometry of core and cladding is incorporated into the equations, they may be combined to produce a wave equation that can be solved for those electromagnetic field distributions that will propagate through the fiber. These allowed distributions of the electromagnetic field across the fiber are referred to as the **modes** of the fiber. They are similar to the modes found in microwave cavities and laser cavities. When the number of allowed modes becomes large, as is the case with large-diameter-core fibers, the ray picture we have used gives an adequate description of light propagation in fibers.

The description of the modes that propagate in a fiber is found by solving the wave equation in cylindrical coordinates for the electric field of the light in the fiber. The cylindrical coordinate system for a fiber is illustrated in **Fig.0.12**. The solutions, which are found to be harmonic (consisting of sine and cosine functions) in space and time, are of the form

$$E(r, \phi, z) = f(r) \cos(\omega t - \beta z + \gamma) \cos(q\phi), \quad (0-14)$$

where ω is the frequency of light in radians/sec ($\omega = 2\pi\nu$, where ν is the linear frequency in Hertz, cycles/sec), β is the **propagation constant**, expressed in radians per unit distance, γ is a phase constant to provide the correct amplitude at time $t = 0$ and position $z = 0$, and q is an integer. The

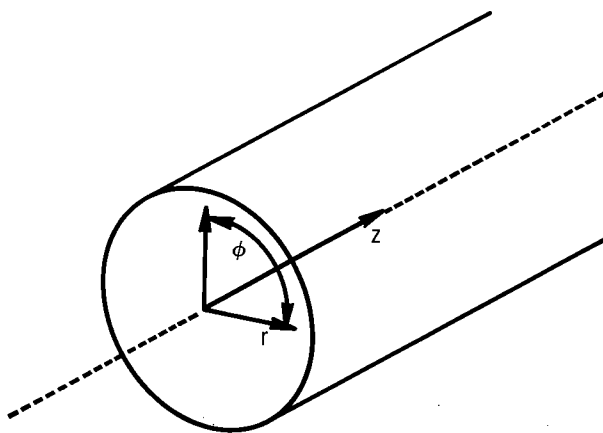

Figure 0.12. Coordinate system for modes in an optical fiber.

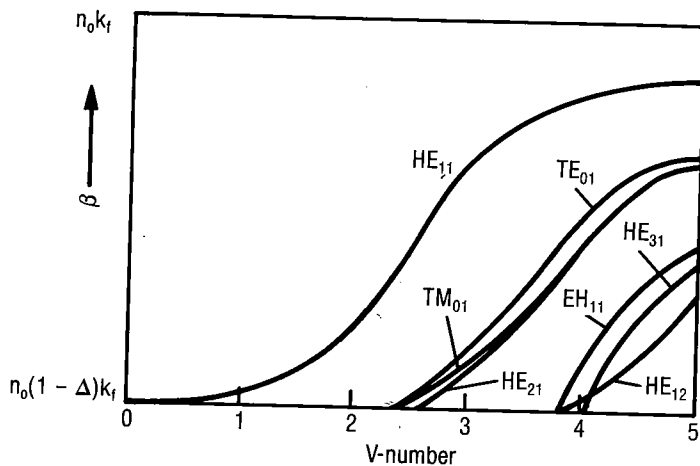

Figure 0.13. Low order modes of an optical fiber. Plot of the propagation constant in a fiber (β) as a function of V-number of a fiber. Each V-number represents a different fiber configuration or a different wavelength of light in a given fiber configuration. [after D.B. Keck in *Fundamentals of Optical Fiber Communication*, 2nd Edition, M. K. Barnoski, ed. see references, Copyright © Academic Press, 1971]

parameter, β , is important for specifying how light propagates in a fiber. In the ray optics description, β is the projection of the propagation vector on the z axis, where the magnitude of the propagation vector is $k = 2\pi n/\lambda_0$, λ_0 being the wavelength of light in vacuum. It is important to make the distinction between the magnitude of the propagation vector, k , and the propagation constant, β , which is the z-component of the propagation vector, in order to avoid later confusion.

Solutions for β , $f(r)$, and q are obtained by substituting Eq. 0-14 into the wave equation. The solutions will depend on the particular fiber geometry and index profile, including both the core and the cladding, under consideration. The step-index profile is one of the few refractive index profiles for which exact solutions may be obtained. For this case the solutions for $f(r)$ are Bessel functions. (Many people are unfamiliar with Bessel functions, since most rarely get beyond trigonometric functions or, perhaps, hyperbolic functions. While trig functions are familiar from high school mathematics, it is hard to find a sine wave in everyday life. The motion of a guitar string is fairly sinusoidal but hard to see because of the high frequency of vibration. However, Bessel functions are easily found. All that is required is a surface that can move freely and a cylindrical boundary to that surface. Anyone's morning cup of coffee will suffice. Just tap the side of the cup and watch the circular waves generated on the surface: Bessel functions!)

An important quantity in determining which modes of an electromagnetic field will be supported by a fiber is a parameter called the **characteristic waveguide parameter** or the **normalized wavenumber**, or, simply, the **V-number** of the fiber. It is written as

$$V = k_f \cdot a \cdot NA, \quad (0-15)$$

where k_f is the free space wavenumber, $2\pi/\lambda_0$, a is the radius of the core, and NA is the numerical aperture of the fiber.

When the propagation constants (β 's) of the fiber modes are plotted as a function of the V-number (remember, each V-number represents a particular wavenumber-core diameter-NA product), it is easy to determine the number of modes that can propagate in a particular fiber. In Fig. 0.13, such a plot is given for some of the lowest order modes. The number of propagating modes is determined by the number of curves that cross a vertical line drawn at the V-number of the fiber. Note that for fibers with $V < 2.405$, only a single mode will propagate in the fiber. This is the single-mode region. The wavelength at which $V = 2.405$ is called the **cut-off wavelength**, denoted by λ_c , because, for a particular product of core diameter and NA, as the wavelength of radiation is increased, this is the wavelength at which all higher-order modes are cut off and only a single mode will propagate in the fiber. A fiber which propagates only the HE_{11} mode is said to be a **single-mode fiber**. For example, the Newport F-SV fiber has a core diameter of $4 \mu\text{m}$ and an NA of 0.11. According to Eq. 0-14, this fiber has a V-number of 2.19 for 633 nm light, putting it well inside the single-mode region. An experiment with this fiber will be done in **Project #3**.

In the weakly-guiding approximation ($\Delta \ll 1$), the exact solutions of waveguide theory, HE_{mn} , can be replaced by a set of modes which are linearly polarized, called the LP modes. (The details of polarization of waves in fibers will be discussed in Section 0.3.2.) These LP modes are combinations of the modes found from the exact theory of the waveguide. These linearly-polarized modes may be characterized by two subscripts, m and n . The first subscript, m , gives the number of azimuthal, or angular, nodes (zeroes) that occur in the electric field distribution of the mode; the second subscript, n , gives the number of radial nodes that occur. They can be identified by pattern in the output of the fiber as it illuminates a screen. The patterns are symmetric about the center of the beam and show bright regions separated by dark regions (the nodes that determine the order numbers m and n). Some of these are shown in Fig. 0.14. It is assumed that the zero field at the outer edge of the field distribution is counted as a node, so $n \geq 1$. For the azimuthal nodes, $m \geq 0$. The lowest order HE_{11} mode consists of two LP₀₁ modes with polarizations at right angles to one another. Fig. 0.15 shows the propagation constants of these modes as a function of V-number. (Compare this figure with the exact solutions in Fig. 0.13.)

When the V number is greater than 2.405 (the value at which the first zero of the zero-order Bessel function occurs), the next linearly-polarized mode, LP₁₁, can be supported by the fiber, so that both the LP₀₁ and LP₁₁ modes will propagate. For a fiber with a V-number of 3.832 (corresponding to the first zero of the first-order Bessel function), two more linearly-polarized modes can propagate: the LP₂₁ and the LP₀₂ modes. By changing the position and angle of the input beam incident on a low-V number multimode fiber, individual linearly-polarized modes can be launched in the fiber and observed at the output. The propagation of individual modes in such a fiber will be observed in Project #4. This will help overcome one of the difficulties of the concept of modes in optical fibers, which is understanding what they are and how they differ from one another.

0.3.2 MODES IN MULTIMODE FIBERS

The multimode fibers used for telecommunications may have a $a = 25 \mu\text{m}$ and $NA = 0.20$ or a $a = 50 \mu\text{m}$ and $NA = 0.30$, so that for 633 nm light, the V-number will be about 50 or 150, respectively. This means that a large number of modes will be supported by the fiber. The amount of light carried by each mode will be determined by the input, or launch, conditions. For example, if the angular spread of the rays from the source is greater than the angular spread that can be accepted by the fiber (the NA of the input radiation is greater than the NA of the fiber) and the radius of the input beam is greater than the core radius of the fiber, then the fiber is said to be **overfilled** (Fig. 0.16 (a)). That is, some of the light which the source will be putting into the fiber cannot be propagated by the fiber. Conversely, when the input beam NA is less than the fiber NA and the input beam radius is less

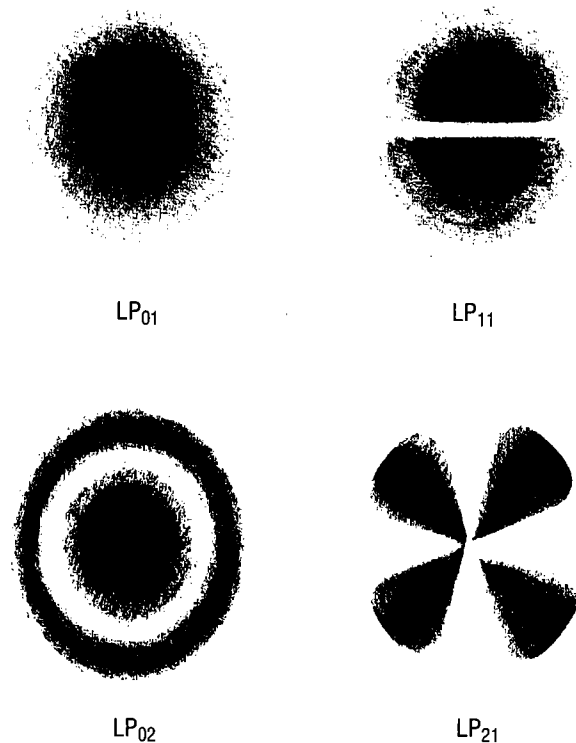

Figure 0.14. Irradiance patterns for some low order linearly polarized modes.

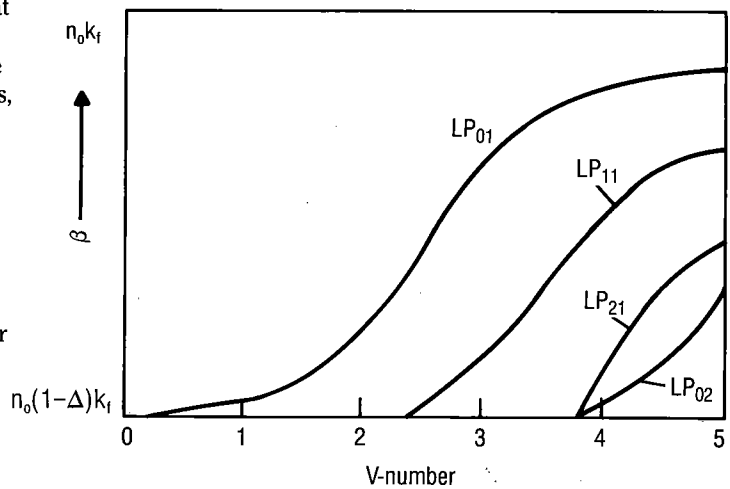

Figure 0.15. Low order linearly polarized modes of an optical fiber. Compare with Figure 0.13.

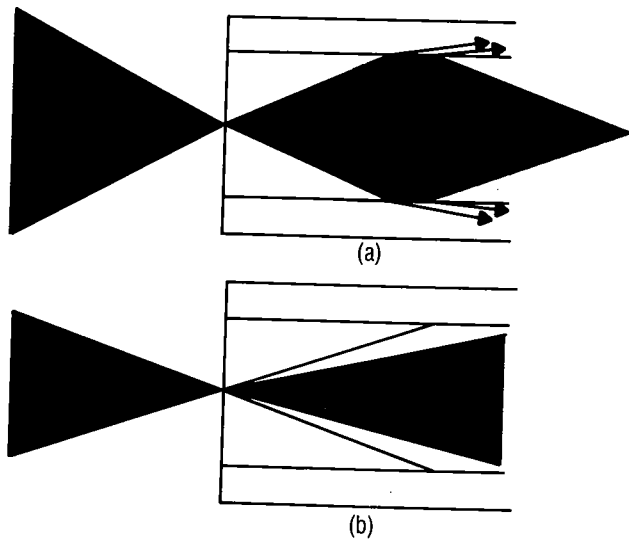

Figure 0.16. Launching conditions in a multimode optical fiber. (a) Overfilled. (b) Underfilled.

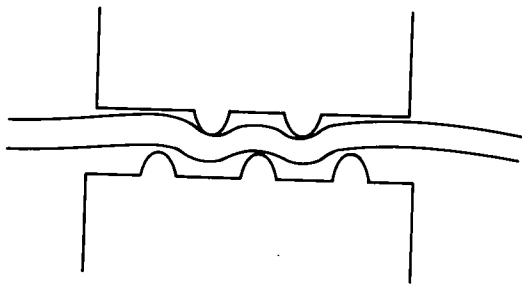

Figure 0.17. Mode scrambler for optical fibers. The bends tend to couple out higher-order and radiation modes and to distribute the light into a distribution of modes that will remain stable over long distances.

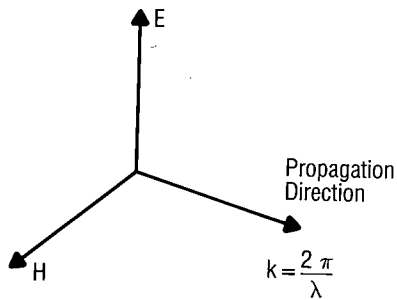

Figure 0.18. Components of an electromagnetic field.

than that of the fiber, the fiber is **underfilled** (Fig. 0.16 (b)) and only low-order modes (low-angle rays in the ray picture) will be excited in the fiber. These two distributions will yield different measured attenuations, with the overfilled case having a higher loss than the underfilled case. In the ray picture, the higher-order rays will spend more of the time near the core-cladding interface and will have more of their evanescent field extending into the fiber cladding, resulting in higher attenuation. Also, if the fiber undergoes bending, the rays at high angles to the fiber axis may no longer satisfy the critical angle condition and not be totally internally reflected. Since power from these modes will radiate into the cladding and increase the attenuation, they are referred to as **radiation modes**. There is another class of modes called **leaky modes**. These modes have part of their electromagnetic energy distribution inside the core and part of their energy distribution in the cladding, but none of their energy distribution is actually at the core-cladding interface. The energy in the core "leaks" into the cladding by a process known, from quantum mechanics, as tunneling. Leaky modes are not true guided modes, but may not be fully attenuated until the light has traveled long distances.

After light has been launched into a fiber and has propagated a considerable distance (which may be several kilometers), a distribution of power within the core of the fiber develops that is essentially independent of further propagation distance. This is called a **stable mode distribution**. To generate an approximation of a stable mode distribution that will not be sensitive to small bends and twists in the fiber orientation, even with only a short length of fiber, a technique called **mode filtering** is used. Mode filtering may be accomplished through the use of **mode scrambling**. Mode scrambling is done by bending the fiber in a series of corrugations, as shown in Fig. 0.17. The effect of these bends is to couple out the light in the radiation and leaky modes and a portion of the light in the higher-order allowed modes and distribute the remaining light among the guided modes of the fiber, producing an approximation of the stable mode distribution. Mode scrambling permits repeatable, accurate measurements of fiber attenuation to be made in the laboratory, even with short lengths of fiber. It will be used in several of the projects in this manual.

0.3.3 POLARIZATION OF WAVES

The electromagnetic field is a vector quantity. Both the electric and magnetic field components are vectors at right angles to each other and both are, in most cases, mutually perpendicular to the propagation vector of the light, as shown in Fig. 0.18. Once the propagation vector whose z-component is β and whose direction along the light ray is known, information about the electric field is all that is required to fully define the field in the medium (the magnetic field can then be determined from this information). The direction of the electric field determines the polarization of the wave.

In many light sources, the polarization of the light varies in a random manner and these sources are said to be **randomly polarized**. Other sources, such as the output of many lasers, are linearly polarized. When light is **linearly polarized**, the electric field vector maintains a constant orientation in space, as depicted in **Fig. 0.19a**. Since the light field is a vector, it can be resolved into its components along two perpendicular axes. If there is a time lag between the two components, which can be translated into a phase delay, then other forms of polarization are created. For example, if the time difference between two orthogonal polarizations is $1/4$ of a cycle (which corresponds to $1/4$ of a wavelength), the phase difference between the two components is 90° . The electric field vector of the wave is the resultant of the two components, and the electric field vector traces out an ellipse in space (**Fig. 0.19b**). For this reason, it is called **elliptically polarized** light. As a special case, if the two components are equal and out of phase by 90° , the wave would be **circularly polarized** as shown in **Fig. 0.19c**. In the case of optical fibers the polarization of light transmitted through them may be preserved or it may be scrambled to yield randomly polarized light, depending on the fiber that is used.

When light interacts with a material, the electrons in the material are set in motion. While most of the light is transmitted by the medium, a small portion of the light is scattered by the electrons and by defects in the medium. In randomly polarized light, the light is scattered in all directions. When the light in the medium is linearly polarized, however, there is little light scattered along the direction of the polarization vector. Most of the light is scattered in or near the plane perpendicular to the polarization direction, as shown in **Fig. 0.20**. This means that if we send linearly polarized light through a medium that changes the polarization direction, but does not scramble it, we can follow the orientation of the polarization through the medium (**Fig. 0.21**). This is done as part of **Project #4**.

In a perfectly symmetric, circular fiber, the two polarized components of the HE_{11} mode (the LP_{01} modes with orthogonal polarizations) travel at the same velocity, since they have identical propagation constants. If the fiber is not perfectly symmetric, then the fiber will be **birefringent**, since the two polarization components have different propagation constants. For example, fibers with elliptical cores will create a birefringence in which the slow and fast axes are along the major and minor axes of the ellipse, respectively. This ellipticity can be either accidental, due to errors in manufacture, or intentional, as part of the fiber design. If the birefringence is to be controlled, it is most often created by building stress regions into the fiber, as shown in the "**bow-tie**" birefringent fiber illustrated in **Fig. 0.22**. Here the slow axis is parallel to the high stress axis of the bow tie and the fast axis is perpendicular to the high stress axis.

If light is launched with a linear component along each of the optical axes, the difference in propagation constants causes the resultant vector of the two polarizations to vary

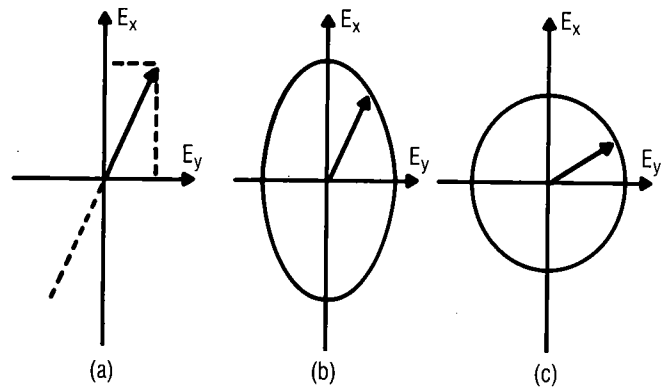

Figure 0.19. Forms of polarization of light. (a) Linear polarization. (b) Elliptical polarization. (c) Circular polarization.

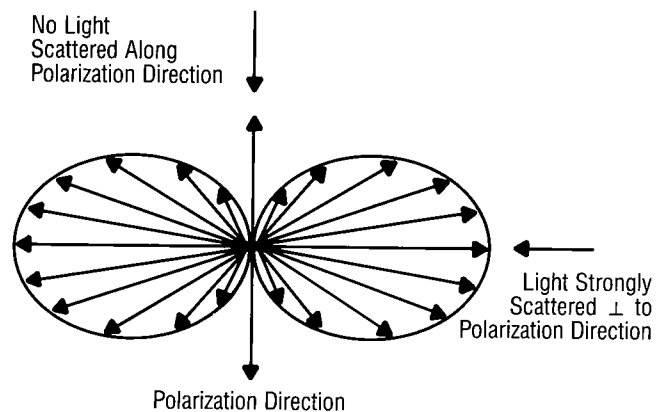

Figure 0.20. Scattering of light by a linearly-polarized field (dipole). Light is scattered strongly at right angles to the dipole direction, but is not scattered at all along the direction of the electric field vector.

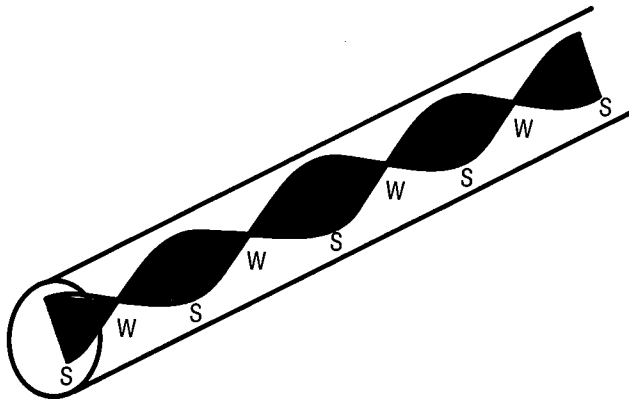

Figure 0.21. Scattering of light by a medium in which the direction of linear polarization changes with distance. W represents weak scattering since the observation direction is along the polarization direction; S represents strong scattering since it is perpendicular to the polarization direction.

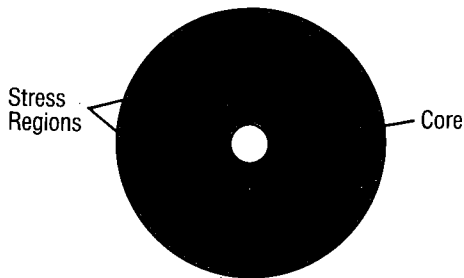

Figure 0.22. Cross section of a polarization-preserving fiber. Stress regions outside the core provide an asymmetry that causes birefringence in the fiber core. Elliptical fibers will also have the same effect.

periodically with distance along the fiber. When the two components are in phase, the light is linearly polarized. As the light propagates and the components go out of phase, the polarization state goes from linear to elliptical and back to linear at a phase difference of 180° . When the two polarization components are made equal in amplitude by launching linearly polarized light at 45° to the optical axes, the polarization progresses from linear, to elliptical, to circular, to elliptical, and back to linear in a plane that is at an angle of 90° to the plane of the original linear polarization. This sequence of alternating polarization states continues along the entire length of the fiber. The distance, L_p , over which the polarization rotates through an entire 360° is known as the **beat length** of the fiber. (Just as the alternate defocusing and refocusing by a graded-index fiber gives rise to a pitch length, a birefringent fiber causes a beat length.) The beat length is related to the birefringence, $\delta n = n_{\text{slow}} - n_{\text{fast}}$, by

$$L_p = 2\pi/\delta\beta, \quad (0-16)$$

where $\delta\beta = 2\pi\delta n/\lambda_0$. This beat length can be observed visually when light from a helium-neon laser is launched into the fiber with its direction of polarization oriented at 45° to the fast axis of the fiber. As was discussed earlier in this section, scattering from centers illuminated by linearly polarized light varies from zero to a maximum as the angle of observation varies from along the polarization direction to perpendicular to it. Thus, as light progresses through a birefringent fiber, the amount of light scattered out at right angles will vary with the state of polarization at each point. In the case of a polarization-preserving fiber with the launch condition described above, the polarization goes from linear to circular and back again. This is slightly different from what was illustrated in **Fig. 0.21**, since that was for the case of rotating linear polarization. However, at points where the polarization is linear, the scattered light is weaker or stronger (depending on the direction of observation) than at the circular polarization positions. By measuring the repetition distances for scattered light variation, the beat length of the fiber can be determined. This will be done as part of **Project #4**.

When linearly-polarized light is launched with the polarization vector parallel to either the fast or slow axis of a high birefringence fiber, the output polarization will still be linearly polarized despite fiber bending. This "polarization-preserving" fiber provides reduced sensitivity to environmental effects. For other launch conditions, however, this will not be true. Instead, the fiber will act to change the polarization of the light; the actual effect on the input polarized light will be determined by the launch conditions, the beat length, and the fiber length. Polarization-preserving fibers have applications wherever the polarization of the transmitted light must be stable and well-defined. These applications include fiber interferometric sensors (studied in **Project #10**), fiber gyroscopes, and heterodyne detection systems.

0.3.4 COHERENCE OF WAVES

The output of many lasers is highly monochromatic. Ideally, the light from the laser is a single color; in actuality, it consists of light within a small band of wavelengths, $\Delta\lambda$. There are a number of ways of describing the degree of monochromaticity in addition to the wavelength bandwidth, $\Delta\lambda$. It can be characterized as a frequency bandwidth, $\Delta\nu$. The two are related by

$$\Delta\nu = \Delta\lambda c/\lambda^2 \text{ or } \Delta\lambda = \Delta\nu c/\nu^2. \quad (0-17)$$

The smaller the bandwidth, the more monochromatic the light source.

Another way of describing the monochromaticity of the source is through its **coherence length**. If a source were totally monochromatic, the output would consist of an electromagnetic field of constant amplitude that oscillates for an infinitely long time with a single output frequency and wavelength. Any deviation in the amplitude or shortening of the length of oscillation results in an increase in the bandwidth of the source or, alternatively, a decrease in the coherence length of the radiation. One may think of this description as trains of waves whose lengths represent the monochromaticity of the source. The relation between the coherence length and the bandwidth is

$$l_c = c/\Delta\nu = \lambda^2/\Delta\lambda. \quad (0-18)$$

0.3.5 INTERFERENCE OF WAVES

When two electromagnetic fields are present in the same place at the same time, their result may be added vectorially, since the fields are vectors. If two fields are linearly polarized in the same direction, the fields may be added point-by-point as scalars. If two electric fields with the same amplitude are in phase, the sum will be twice as large; if they are 180° out of phase, the fields will cancel point by point and resultant field is zero, as shown in Fig. 0.23. The phenomenon of two or more electromagnetic fields summing to give a resultant is called **interference**. When the fields are in phase, it is called **constructive interference**, and when the fields are 180° out of phase, it is called **destructive interference**. In many optics arrangements the path lengths alternatively vary through constructive and destructive interference, producing a series of dark and light fringes. From the fringe patterns and their changes as physical conditions in the interfering paths are changed, it is possible to measure extremely small changes in distances and refractive indices. In all of this we have the same polarization direction. If the fields have polarizations at right angles to each other, the resultant would be the vector addition of the two fields, but no constructive or destructive interference would occur and no fringes would be visible. A fuller explanation of interference and interference fringes is available in a number of elementary optics texts.

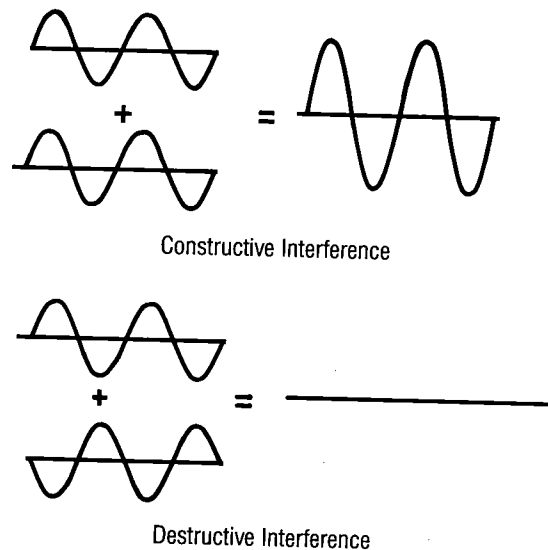

Figure 0.23. Illustrations of the interference of two waves.

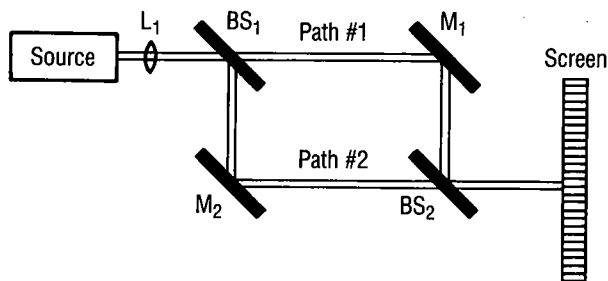

Figure 0.24. Mach-Zehnder interferometer. L: collimating lens; BS: beamsplitter; M: mirror.

One geometry that exhibits interference is the **Mach-Zehnder interferometer**, shown in **Fig. 0.24**. The source is collimated by lens L_1 and the collimated beam is divided by beamsplitter BS_1 . A **beamsplitter** is a component that transmits a fraction of the light incident on it and reflects the rest, assuming that there is no absorption by it. In most cases, the ratio of transmission to reflection is 50/50. The split beams are then redirected by mirrors M_1 and M_2 to be recombined at a second beamsplitter BS_2 . Their interference is seen on the screen S . If there is any change in optical path length introduced into either path, or arm, of the interferometer, the fringe pattern will change in a manner that will, in most cases, enable an observer to measure that change. In **Project #10**, a fiber optics version of the Mach-Zehnder interferometer will be constructed and examined. In this device, the mirrors will be replaced by optical fibers and beamsplitter BS_1 will be replaced with a component called a bidirectional coupler.

0.4 TRANSMITTING POWER THROUGH OPTICAL FIBERS

0.4.1 LOSSES IN FIBERS

In all of the above discussion, it has been assumed that the light travels down the fiber without any losses beyond those from radiation and leaky modes and some higher-order modes that are coupled out into the cladding.

When light is transmitted through an absorbing medium, the irradiance falls exponentially with the distance of transmission. This relation, called **Beer's Law**, can be expressed as

$$I(z) = I(0) \exp(-\Gamma z) \quad (0-19)$$

where $I(z)$ is the irradiance at a distance z from a point $z = 0$, and Γ is the **attenuation coefficient**, expressed in units reciprocal to the units of z . In some fields of physics and chemistry, where absorption by a material has been carefully measured, the amount of absorption at a particular wavelength for a specific path length, such as 1 cm, can be used to measure the concentration of the absorbing material in a solution.

Although the absorption coefficient can be expressed in units of reciprocal length for exponential decay, in the field of fiber optics, as well as in most of the communications field, the absorption is expressed in units of dB/km (dB stand for decibels, tenths of a logarithmic unit). In this case, exponential decay is expressed using the base 10 instead of the base e ($= 2.7182818\dots$) as

$$I(z) = I(0) 10^{-(\Gamma z/10)}, \quad (0-20)$$

where z is in kilometers and Γ is now expressed in decibels per kilometer (dB/km). Thus, a fiber of one kilometer length with an absorption coefficient of 10 dB/km permits $I(z)/I(0) = 10^{-(10 \times 1/10)} = 0.10$ or 10% of the input power to be transmitted through the fiber. **Project #2** involves the measurement of the attenuation in an optical fiber.

The losses in fibers are wavelength dependent. That is, light of different wavelengths introduced into the same fiber will suffer different amounts of loss. **Fig. 0.25** shows the attenuation in dB/km of a typical optical fiber as a function of wavelength.

Although the exponential dependence was described for absorption losses, the same mathematics can be used for other sources of losses in fibers. Optical transmission losses in fibers are due to several mechanisms. First, optical fibers are limited in the short wavelength region (toward the visible and ultraviolet) by absorption bands of the material and by scattering from inhomogeneities in the refractive index of the fiber. These inhomogeneities are due to thermal fluctuations when the fiber is in the molten state. As the fiber solidifies, these fluctuations cause refractive index variations on a scale smaller than the parabolic variation that is imposed upon graded-index fibers. Scattering off of the inhomogeneities is known as **Rayleigh scattering** and is proportional to λ^{-4} , where λ is the wavelength of the light. (This same phenomenon is responsible for the color of the sky. The stronger scattering of light at shorter wavelengths gives the sky its blue color.)

In the long wavelength region, infrared absorption bands of the material limit the long wavelength end of the radiation spectrum to about 1600 nm. These two mechanisms are the ultimate limit for fiber losses. The highest quality fibers are sometimes characterized by how closely they approach the Rayleigh scattering limit, which is about 0.17 dB/km at 1550 nm.

At one time metal ions were the major source of absorption by impurities in optical fibers. It was the elimination of these ions that produced low-loss optical fibers. Today, the only impurity of consequence in optical fibers is water in the form of the hydroxyl ion (OH^-), whose absorption bands at 950, 1250, and 1380 nm dominate the excess loss in today's fibers. They are evident in the absorption spectrum shown in **Fig. 0.25**.

0.4.2 LIGHT SOURCES FOR OPTICAL FIBERS

Although light of many wavelengths and degrees of coherence may be transmitted by an optical fiber, there are a number of sources that are fairly convenient and efficient in coupling light into a fiber.

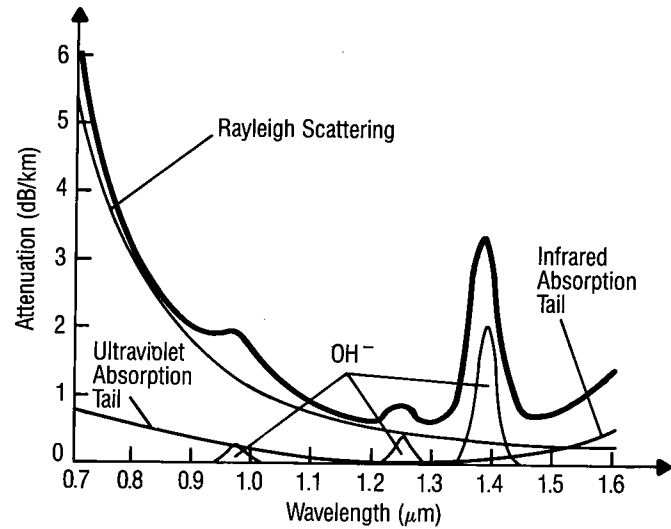

Figure 0.25. Attenuation of an optical fiber as a function of wavelength.

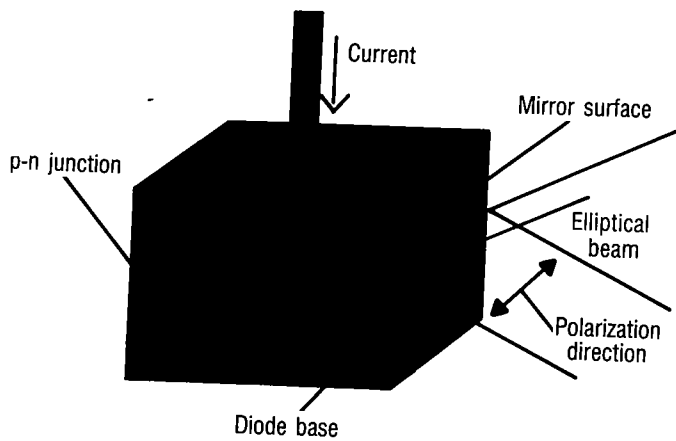

Figure 0.26. Construction of a simple semiconductor diode. Light emitting diodes and injection laser diodes have a similar basic construction, although the actual structure of the laser device is considerably more complicated.

The small red indicator lights that we see in smoke detectors and electronic panel lights are **light emitting diodes (LED's)**. The name is quite descriptive, since these devices are nothing more than special semiconductor diodes that emit light. They are made of semiconductors, such as gallium arsenide, to which small amounts of atomic impurities have been added to raise the conductivity. The carrier of electrical current is either an electron or a hole (the absence of an electron). The material in which electrons are the major carrier of current is called n-type material and the material in which holes are the major carrier is called p-type. A diode is created when pieces of n-type and p-type material are constructed next to one another, as in **Fig. 0.26**. The interface plane between them is called the junction. When a voltage is applied across the diode junction so that the diode conducts, it emits light which is radiation resulting from the recombination of electrons and holes. This radiation is called, appropriately, **recombination radiation**. The amount of light output is proportional to the number of electron-hole pairs that recombine in the diode and this is proportional to the diode current. Therefore, the optical power-current curve of an LED will be a straight line. The wavelength of the emitted radiation in an LED depends on the differences between the energies of the electrons in the n-type material and holes in the p-type material. The bandwidth of the radiation is broad compared to that of laser sources.

Although the construction of **current injection laser diodes (ILD's)** is much more elaborate than LED's the two are shown in **Fig. 0.26** as being similar. Both in the simplest illustration and in the basic principles of operation, these two devices are similar. Current is injected into the diode by applying a voltage across the diode. However, the current densities are considerably greater in an ILD than those in an LED. Instead of electron-hole pairs recombining spontaneously as in an LED, in an ILD this enormous current flow stimulates the pairs to emit coherently, creating a more powerful output with a narrower bandwidth. This process is called **stimulated emission**. The optical power-current curve of the ILD is different from that of the LED in that the current must reach a threshold value before lasing can occur. The output then increases rapidly in proportion to the current in excess of the threshold current. The stimulated process just described is enhanced by the surfaces of the semiconductor crystal that serve as partially reflecting mirrors to redirect part of the laser output back into the junction region. These mirrors also cause the output of the ILD to be partially collimated, although diffraction of the light by the edges of the junction region causes the light to be directed into a fan-shaped beam with a divergence which is typically about 15° by 30° . The larger divergence angle is in the direction perpendicular to the junction plane, as shown in **Fig. 0.26**.

In contrast to the solid state semiconductor medium of the ILD, the lasing medium of the helium-neon (HeNe) laser is a mixture of helium and neon gases which is excited by an electrical current, creating a light-emitting discharge similar to those seen in neon signs. The difference between the neon sign and the HeNe laser is the proportions of the gas mixture, a narrow discharge path in the glass tube, and reflecting end mirrors, as shown in **Fig. 0.27**. The output wavelength of the HeNe laser is usually in the red at 633 nm, although outputs at other wavelengths in the visible and infrared can be obtained by using different sorts of mirrors with higher reflectivities at the allowed wavelengths. The output is more highly collimated than the output of the ILD. For a typical HeNe laser, the beam divergence is about 1 milliradian (mrad) or 0.06° .

The polarization of radiation in a fiber optics system depends on the type of source that is used. Some HeNe lasers possess a high degree of linear polarization; others are randomly polarized. Their polarization is usually determined by the details of the laser construction. The output of an LED is randomly polarized, while that of an ILD is polarized parallel to the plane of the p-n junction. The polarization of a source can be checked by observing the variation in power on a detector as a polarizer is rotated in front of the source. A linearly polarized source will show large variations in the transmitted power as the polarizer is rotated, while randomly polarized or circularly polarized light will show little or no variation. Separating circularly from randomly polarized light requires the use of an optical component known as a waveplate.

There are other sources that might be considered for use in fiber optics system: the sun, tungsten lamps, fluorescent light neon lamps, electric arcs, etc. However, most of these sources are extended sources. That is, they have a large emission area compared to the sources already discussed. To introduce light from these sources into a fiber requires that some optical system be constructed to refocus the source onto the fiber end. The larger and more divergent the source, the more difficult it is to couple light into the system.

0.4.3 COUPLING SOURCES TO FIBERS

One objective in any fiber optics system is to insert as much power into the system with as little loss as possible. This allows the use of lower power sources in a system, reducing the cost and enhancing the reliability, since the source does not have to be operated near its maximum rated power. Attention paid to coupling a source to a fiber or a fiber to other components will be repaid in a more reliable and cheaper system. (Losses which occur in fiber-to-fiber coupling and splicing will be discussed and measured in **Project #6**.)

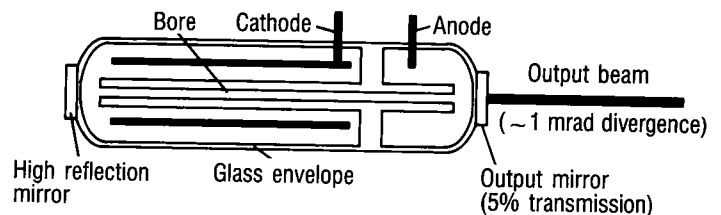

Figure 0.27. Construction of a Helium-Neon laser tube.

The direction of the radiation that is emitted from a source must be considered in the field of fiber optics, since that radiation has to be collected and focused onto a fiber end. Sources can range from isotropic (emitting in all directions) to collimated (emitting in only one direction). In general, the angular distribution of the source can be expressed as

$$B(\theta) = B_0 (\cos \theta)^m, \theta < \theta_{\max}, \quad (0-22)$$

where θ_{\max} is the maximum angle from the normal at which the light is emitted and is determined by the geometry of the source. If $m = 1$ in Eq. 0-22, the source is called a **Lambertian source**. Many non-laser sources closely approximate Lambertian sources. For a collimated source, m is very large. For intermediate cases, the source may be considered to be a partially collimated source. The angular distribution of an LED and an ILD will be measured in **Project #5**.

The ability of a fiber to accept radiation can be characterized by its NA. We can describe the range of angles into which a source emits by a similar NA. The definition of the maximum angle of the source is not as easily determined as the maximum angle of a fiber with its critical angle, since the light may be emitted into a distribution of angles that does not have a precisely defined cut off.

In some cases, the light from the source is so divergent and the source is so large that the source must be reimaged on the fiber end face by a short focal length lens. For such a source, the lens is overfilled and the marginal rays, those at the edge of the cone of light, are determined by the size of the lens that is used. In that case, the NA of the source is given by

$$NA_{\text{extended}} = n \sin \theta, \quad (0-23)$$

where $\theta = \tan^{-1} r/d$, with r = radius of the lens and d = image distance, as shown in **Fig. 0.28**.

For collimated laser sources, the lens is usually under-filled if it is placed close to the source. The light comes to a focus at the focal point of the lens. The beam then has a divergence half-angle that is approximately equal to the ratio of the beam waist radius before the lens, r_0 , to the focal length of the lens. Thus, the NA of the beam is given by

$$NA_{\text{beam}} = n \sin (r_0/f). \quad (0-24)$$

There are four parameters which affect the efficiency of source-fiber coupling, the NA's of the source and the fiber and the dimensions of the source and the fiber core. It is possible to show that the product of the source diameter and the NA of the source is a constant no matter what the focal length of the imaging lens may be. By comparing this value to the product of the fiber core diameter times the fiber NA, it is possible to determine whether a lens may be chosen that can image the

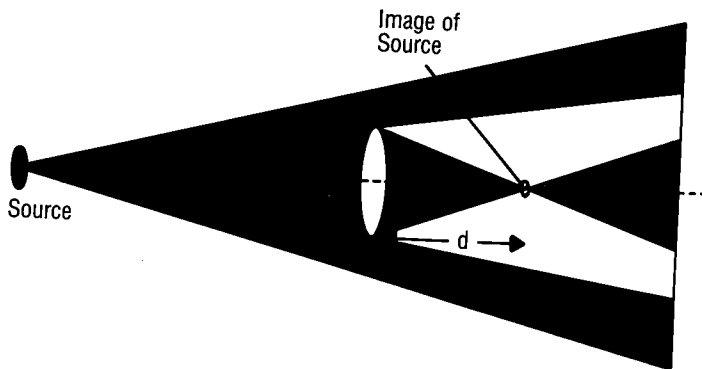

Figure 0.28. Calculation of the NA of an extended source.

source onto the fiber core without overfilling the fiber. Overfilling is marked by a source NA which is larger than the fiber NA. If the diameter-NA product of the source is larger than that of its fiber counterpart, reducing a source NA to fit a fiber NA will not increase the coupling since that action enlarges the diameter of the source image on the fiber face. Thus, a careful consideration of the diameter-NA products will keep someone from trying to do the impossible. This same approach can be applied also to coupling between fibers of different sizes and NA's. Further details of coupling will be discussed and illustrated in **Project #5**.

0.5 APPLICATIONS

Most of the applications of fiber optics systems fall into one of three categories: communications, sensors, and power distribution. In this section, each will be described briefly.

By far the most extensive use of fiber optics is in the field of communications. It encompasses short links between computers and telecommunications devices, the so-called local area networks (LAN's) and longer distance connections that include those between the metropolitan areas of the Northeastern United States and those between America and the European continent. A fiber optics communication link will be constructed in **Project #8**.

When information is sent through a fiber optics system, it is encoded on the light wave by changing the light irradiance as a function of time. This process of varying the light level with time is called **modulation**. There are two types of modulation: analog and digital. Analog modulation consists of changing the light level in a continuous manner, while with digital modulation, the information is encoded through a series of pulses separated by spaces, as shown in **Fig. 0.29**. The absence or presence of a pulse at some point on the stream of pulses represents one element, or bit, of information.

The performance of a system using analog modulation is determined by how faithfully it reproduces the signal and by the smallest signal that can be transmitted, which is limited by random or extraneous noise in the system. Part of this is due to the type of detector that is used to convert the modulated light signal back into an electrical signal and part is due to the system itself. The ratio of the detected signal to the smallest signal which can be distinguished from the noise is called the **signal-to-noise ratio (SNR)**. This will be discussed as part of **Project #8**. In the case of digital systems, the faithful reproduction of signal level is not required, which makes such systems superior in the presence of noise sources. All that is required is that pulses be transmitted with sufficient power for the detector and electronics to determine the presence or absence of the pulse. Performance in digital systems is given in terms of the **bit error rate (BER)**, the fraction of bits sent that are determined to be in error when compared with the original digital information. BER's of less than 10^{-9} are generally required for a fiber optic digital communication link to be considered a high-quality system.

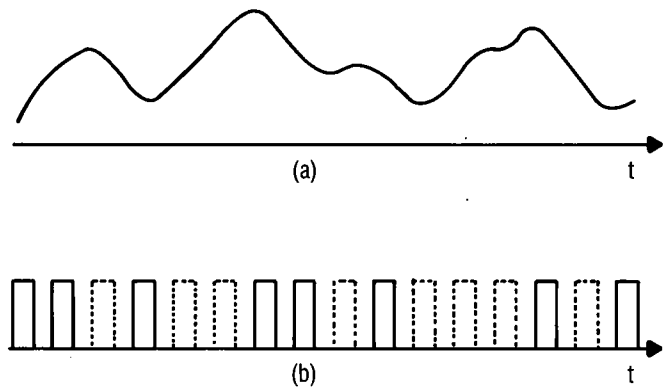

Figure 0.29. Two types of signal modulation. (a) analog. (b) digital.

Another application involves the use of optical fiber sensors to measure physical parameters. Because of their small diameter, sensors made of optical fibers can be fit into tight geometries where conventional sensors would be too large. Also, because the fiber medium is non-conducting, fiber sensors can be used in dangerous circumstances, such as explosive atmospheres. Sensors can be used to measure physical parameters such as temperature and pressure and engineering information such as liquid levels and distances. Four different types of multimode intensity sensors will be explored in **Project #9** and in **Project #10** a single mode interferometric sensor will be constructed.

Persons who have not studied fiber optics tend to think of them as optical water hoses. But as we have seen, the launching conditions, the fiber NA, the mode distribution in the fiber, and the fiber absorption and scattering losses all can contribute to reducing the usefulness of a fiber as a conductor of optical power. There are, however, certain fields where the transmission of optical power by optical fibers has proved useful.

In the field of medicine, the ability to insert optical fibers inside small hollow tubes that are pushed through small incisions in the body has provided a number of successful surgical procedures that do not call for massive cutting of tissues and yet still provide treatment for diseased parts of the body from the output of the optical fiber. Parallel to the power carrying optical fiber there is usually a second tube with many strands of optical fiber arranged in a precise manner that conduct illuminating light to the location of the treatment and carry an image of the treatment site back to the surgeon. Many of the treatments are still in the experimental phase. One of the most sought after products is an optical fiber that would carry large amounts of long wavelength infrared radiation from a carbon dioxide laser. The focused output of this laser makes an ideal surgical scalpel, but in the near term there are no fibers of sufficient flexibility, low cost, and low absorption at the CO₂ laser wavelength that this specific application will become widespread.

There are a number of applications in the field of material processing where the delivery of laser power to a location would be an ideal method of operation. In dusty and difficult environments, the replacement of multiple lens-based optical power delivery systems with fiber-based systems is useful because of the reduction in down time and maintenance. Usually, the divergent output of the fiber must be refocused by a lens to produce the required irradiance to heat treat, melt, or vaporize an area of the material being processed. Depending on the wavelength of the radiation being used and the type of fiber employed, there are maximum values of power that can be delivered by such systems.